

PICHON

**MUCK
MASTER**



MUCK SPREADERS FROM 6 TO 24 M³



M850: 8m³



M1450: 14m³



M1655: 16m³



M2070: 20m³

A NEW SPREADING CONCEPT

Complementary product to slurry tankers, PICHON also manufacture a full line-up of rear discharge muck spreaders: the Muck Master.

This range of muck spreaders is especially designed for farmers and contractors who are looking for a unique heavy duty construction machine.

At PICHON, we make the significant choice to manufacture our spreaders by using a unique and innovative design of a narrow body. Our objective being to find the best compromise between width and length while keeping a high rear frame and oversized beaters in order to ensure the consistency of the spreading. This body shape also enables the use of high diameter wheels reducing the requirements of towing power.

Following the PICHON tradition, the **Muck Master** range is fully manufactured with galvanised steel. The spreaders are entirely adapted to cope with the most compacted materials thanks to a unique robust design and a system of vertical twin beaters. The unequalled diameter, the height and the angle of inclination of the PICHON beaters give the **Muck Master** the ability to spread various solid products in challenging working conditions from 6 up to 20m wide.

PICHON also offer a range of accessories in order to handle any type of solid manure and to spread more accurately (hydraulic guillotine door, rear hood, bottom deflectors, weigh cells, spinning deck, application rate control, ISOBUS...).

AN ACCURATE HEAPED CAPACITY FOR ALL THE MUCK MASTER MODELS

PICHON offer 20 models of muck spreaders from 6 to 24m³. Manufactured for professional purpose, it meets and exceeds the most demanding requirements in accordance with the natural constraints of spreading activity.

The naming of the PICHON range Muck Master corresponds to the accurate cubic capacity of the machine calculated with the inside dimensions of the body (length, height and width). The cubic capacity is heaped level and takes into consideration the fact that there is a guillotine door on the machine.



5 YEARS WARRANTY



PICHON offer a 5 years warranty on the spreader body/frame and chassis.

The warranty covers any premature strain/distortion during a normal operation of the machine

GALVANISATION



The Muck Master range is fully protected by a hot galvanisation process (bath of zinc at 450° C), giving a longer lifetime to the spreader.

EXPERIENCE

With over 45 years of experience and knowledge, the PICHON team is able to analyse each specific demand in order to advise and offer the ideal customised solution.

DRIVE SAFELY



In addition to an incredible performance on the fields, you will be able to drive a machine which is as smooth on the road as it is on the fields.

All the spreaders are equipped with reinforced axles and oversized brakes (air and/or hydraulic). As standard they come with a fully galvanised sprung drawbar with multi-leaf springs, truck lights and a flashing beacon. Thanks to this standard equipment, the machine is already approved to 40km/h in many European countries.

ENGINEERED FOR STRENGTH

PICCHON select the most reliable components for their technical and mechanical characteristics.

The **Muck Master** continues the manufacturing of excellence from PICCHON with a fully galvanised body as standard, assembled with stainless steel bolts. The spreaders are also equipped with a slatted top grill at the front to ensure protection to the user and also allow visibility inside the machine while discharging.

Upon this reinforced structure, PICCHON have made the choice to install vertical twin beaters with unequalled diameters and also reversible blades made of Hardox steel. The beaters are fitted on a monobloc gearbox driven by a 55mm diameter shaft allowing a better transmission of speed and torque. The heavy duty built screws (from 8 to 12mm according to the model) are welded to large diameter tubes.

The floor is composed of U-shaped slats (70x40mm) and marine chains (12mm on M640 and 16mm diameter as standard on the other models). The bearings of the floor transmission are protected by a galvanised frame. The maintenance is made easier thanks to centralised greasing points. The floor is driven by a reducer with high torque and comes with variable speed control (external manual regulator as standard, in-cab electric available as an option).

In order to prevent any damages to the body while loading the muck, wooden and steel extensions can be fitted (and retrofitted) on the sides.



BUILT TO SUIT YOUR SPECIFIC NEEDS



SMOOTH ON THE FIELD

SIMPLE OPERATION

EASY MAINTENANCE

OPTIONS FOR YOUR COMFORT

AXLE SUSPENSION

The spreader must fit all working conditions in the field but also be smooth on the road. **PICHON offer a wide range of axles: fixed, rear steering or forced steering, with sprung or hydraulic suspension (passive or active).**

In addition, the DELTA suspension designed by PICHON especially copes with intensive use in extreme working conditions, as it allows a better ground clearance.

The user can choose free or forced steering axles to optimize the manoeuvrability, to reduce tyre wear and to increase road safety.



DRAWBAR SUSPENSION

Thanks to their specific design, the PICHON drawbars transfer perfectly the towing efforts to the chassis and the tractor. **Galvanised as standard, there are two models available: multi leaf springs as standard or hydraulic suspension as option.**

The hydraulic suspension (optional) is used to adjust the slope angle of the drawbar and improve the traction of the machine.

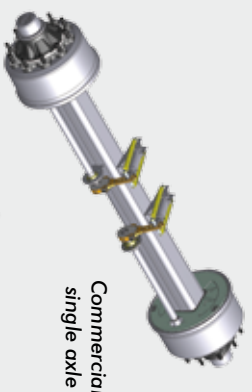

Commercial
single axle

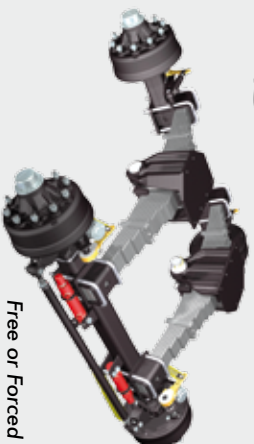

Free or Forced
steering Bogie

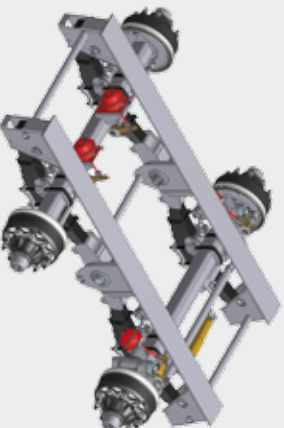

Free or Forced steering
lowered Tandem

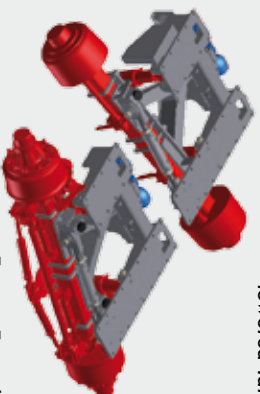

Free or Forced steering
Delta suspension

A WIDE CHOICE OF CONTROL BOXES



Depending on the specifications chosen by the customer on the machine, PICHON can supply various models of control boxes (electric or hydraulic).

As standard, a variable external speed control of floor (from 1 to 10, see picture above) is equipped on the whole Muck Master range.

The user is offered the possibility to choose an in-cab electric control box in order to adjust the speed of the floor from inside the tractor cab.

Also available as an option, PICHON offer a full in-cab control box including the speed control of floor and additional hydraulic functions (opening/closing of the guillotine door, use of the rear hood...).



A MULTI-PURPOSE MACHINE BUILT TO YOUR NEEDS

In addition to the oversized beaters, PICHON offer a wide range of options to meet all the spreading requirements.

The guillotine door avoids any blockage of muck in-between the beaters before they are turned on by the user. The door also enables the user to regulate the spreading flow as well as decreases the possible loss of material on the road.

Hydraulic side deflectors increase the spreading accuracy by controlling the angle where the product is spread. It is a convenient option for people who have to spread near roads or banks.

A rear spreading hood can be mounted (or retrofitted) to the rear frame of every Muck Master models. Once fitted, light products such as chicken manure, composts and lime can be spread evenly and accurately at low application rates (less than 10 tons/hectare). The user only has to close the back doors when he has to spread light products and open them when he has to spread heavier muck. This makes the machine more versatile for the user and there is no need to remove the doors as they stay permanently on the machine.

A proper rear hood with spinning deck is also available with horizontal beaters Ø800 and Ø1080 bottom discs for users who want to spread lighter materials up to 24m wide, at a lower dose.



Hydraulic side deflector



Right & left deflectors



Rear Hood on vertical beaters



Rear Hood on vertical beaters



Rear Hood on vertical beaters



Horizontal beaters with spinning deck

GIVE VALUE TO YOUR SPREADING

The spreading of organic manure must fit farming requirements. It is thus important to respect the optimal spreading periods.

As manure is a much diversified organic fertilizer, it is necessary to spread the right dose, at the right time with the right tool to get the best benefits on the soil.

That is why the choice of the muck spreader is the key success factor of the organic fertilization.

Manure / Season *	Winter	Spring	Summer	Autumn
Beef	Orange	White	Blue	Green
Pig	Orange	White	Blue	Green
Poultry	Blue	Orange	White	White
Compost	Green	Green	Yellow	Green

Rape Orange Maize Green Grassland Yellow Cereal

* example for temperate climate

PRECISION SPREADING



The PICHON application rate control enables the user to control the specific dose by adjusting the floor speed according to the spreading width. Sensors are fitted on the axle(s) of the machine so that the system knows the accurate speed of the spreader.

The operation is very simple: The user enters the type of muck to be spread, the quantity per hectare (or acre) and the requested spreading width on his touch screen control panel. The speed of the floor will vary accordingly to respect the dose.

PICHON also offer a combined weigh cells with the application rate control for more accurate spreading. The total weight is calculated and allows the user to spread the right quantity.

	From 3 to 10 t/ha	From 10 to 20 t/ha	From 20 to 50 t/ha
Compost	Green	White	White
Poultry Manure	White	Green	White
Beef Manure	White	White	Green

CUSTOMISE YOUR MACHINE

Each model of the PICHON Muck Master range can be tailor-made thanks to a large choice of options.

16mm marine chains can be replaced by 20mm VAUCANSON chains or removable floor slats with flat chains, combined with rolls cleaner or galvanised chain protectors.

For a better comfort, the spreader can be equipped with a hydraulic drive unit (80L/min) to maintain the same floor speed when tractor change is required.

Giving value to the organic manure is the best choice for the environment but also for the savings!

That is the reason why PICHON offer so many possibilities to customise your machine.

A complete overview of our options is available page 13.



Load counter



Hydraulic chain tension



Removable floor slats with flat chains



Beders tube Ø323 mm and 62 knives



Curved plates for light products



Mechanical height indicator of guillotine door



Hydraulic height indicator of guillotine door



Mudguards



Painting on muck speader and mudguards



Protected hydraulic drive unit (80L/min)

TECHNICAL DATA

Model	M³	Axle / Studs	Hydraulic Brakes	Reducer	U shape slats 70mm	Beaters diameter	Screw thickness	Reversible blades	Rotation speed of the beaters (at 1000 rpm)
M640	6	Axle □ 80 / 8	350 x 60	2 500 N.m	20 (tubular)	670 mm	6 mm	40	380 rpm (540 rpm)
M850	8	Axle □ 90 / 10	400 x 80	5 000 N.m	34	885 mm	8 mm	32	480 rpm
M1050	10	Axle □ 90 / 10	400 x 80	5 000 N.m	34	885 mm	8 mm	32	480 rpm
M1250	12	Commercial axle □ 110 / 10	406 x 120	5 000 N.m	34	885 mm	8 mm	42	480 rpm
M1250B	12	Free steering PICHON boggie. Axle 80 / 8	400 x 80	5 000 N.m	34	885 mm	8 mm	42	480 rpm
M945	9	Axle □ 90 / 10	400 x 80	5 000 N.m	29	885 mm	8 mm	42	480 rpm
M1045	10	Axle □ 90 / 10	400 x 80	5 000 N.m	29	885 mm	8 mm	42	480 rpm
M1350	13	Commercial axle □ 130 / 10	406 x 120	5 000 N.m	34	1035 mm	10 mm	46	422 rpm
M1350B	13	Free steering PICHON boggie. Axle 90 / 8	400 x 80	5 000 N.m	34	1035 mm	10 mm	46	422 rpm
M1450	14	Commercial axle □ 130 / 10	406 x 120	5 000 N.m	34	1035 mm	10 mm	46	422 rpm
M1450B	14	Free steering PICHON boggie. Axle 90 / 8	400 x 80	5 000 N.m	34	1035 mm	10 mm	46	422 rpm
M1555	15	Commercial axle □ 130 / 10	406 x 140	5 000 N.m	37	1035 mm	10 mm	46	422 rpm
M1655	16	Commercial axle □ 150 / 10	420 x 180	10 000 N.m	37	1035 mm	12 mm	52	422 rpm
M1655B	16	Free steering PICHON boggie. Axle 130 / 10	400 x 80	10 000 N.m	37	1035 mm	12 mm	52	422 rpm
M1655T	16	Free steering PICHON tandem. Axle 130 / 10	400 x 80	10 000 N.m	37	1035 mm	12 mm	52	422 rpm
M1855	18	Essieu roulier □ 150 / 10	420 x 180	10 000 N.m	37	1035 mm	12 mm	52	422 rpm
M1855B	18	Free steering PICHON boggie. Axle 30 / 10	400 x 80	10 000 N.m	37	1035 mm	12 mm	52	422 rpm
M1855T	18	Free steering PICHON tandem. Axle 130 / 10	400 x 80	10 000 N.m	37	1035 mm	12 mm	52	422 rpm
M2070	20	Free steering PICHON tandem. Axle 130 / 10	406 x 120	10 000 N.m	45	1035 mm	12 mm	52	422 rpm
M2470	24	Free steering PICHON tandem. Axle 150 / 10	420 x 180	10 000 N.m	45	1035 mm	12 mm	52	422 rpm

STANDARD EQUIPMENT

STRUCTURE:

- fully galvanised
- axle recessed in the chassis
- chassis 6mm thick
- removable body side board
- front frame 4 and 6 mm thickness
- stainless steel bolts
- rear frame 6 and 8 mm thickness
- wide box belt
- folding ladder
- big front protection frame

TRANSPORT:

- jack: manual from M640 to M1450 or hydraulic from M1555 to M2470
- galvanised sprung drawbar
- bolted ring hitch

PROFILES OF THE WHEELS



21.3 R 24 AS



Alliance 388



550/60 - 22.5



Alliance 845



Alliance 347



Alliance 846



Alliance 360



Mitras AC70



Alliance 380



Michelin Cargo XBib



Vredestein Flor Trac



BKT 630



BKT RT 657

OPTIONS

	M640	M850	M1050	M1250 M1250B	M945	M1045	M1350 M1350B	M1450 M1450B	M1555	M1655	M1655B M1655T	M1855	M1855B M1855T	M2070	M2470
Ø80mm bolted ball hitch instead of ring hitch															
Hydraulic jack instead of manual jack															
Drawbar foot															
Hydraulic suspension on drawbar															
Extra for wide angle PTO shaft 6 splines															
Mudguards															
LED truck lights with rear hood or 2 side deflectors only															
Air brakes															
Air and hydraulic brakes															
DELTA Active hydraulic suspension 2 modules															
Removable floor slats															
Floor with PICHON flat chains															
Floor with Vaucanson Ø20mm chains															
Hydraulic chain tension (hydraulic jack obligatory)															
Brackets and wooden extensions (+ 150mm)															
Silage kit															
Chain protection (for lime product and heavy manure)															
Hydraulic guillotine door															
Right side hydraulic deflector															
Left side hydraulic deflector															
Right bottom deflector on rear hood															
Left bottom deflector on rear hood															
Rear hood with spinning discs															
Spinning deck with 2 horizontal beaters Ø800 + 2 discs Ø1080															
Beaters with Ø323mm tube and 62 blades															
Mechanical height indicator of guillotine door															
Hydraulic guillotine door level indicator															
Curved blades on first bottom screw															
Curved blades on the entire screw															
In-cab electric floor control															
Load counter															
Hydraulic drive unit (oil quantity delivered 80L - 1000 RPM PTO)															
Flowmeter simplified (1 or 2 functions)															
Weighing system only with 4" screen															
Flowmeter with for weighing system and door sensor															
ISOBUS flowmeter with for weighing system (with or without screen)															

LEGEND: AVAILABLE OPTION STANDARD OPTION NOT AVAILABLE

DIMENSIONS OF THE MUCK MASTER RANGE

Models	A	B	C	D	E	F	G	H	I
M640	6 684 mm	800 mm	1 111 mm	1 597 mm	3 470 mm	4 250 mm	4 230 mm	1 125 mm	2 000 mm
M850	8 060 mm	850 mm	1 265 mm	1 650 mm	4 983 mm	5 150 mm	5 699 mm	1 235 mm	2 150 mm
M1050	8 060 mm	1 100 mm	1 515 mm	1 650 mm	4 983 mm	5 150 mm	5 725 mm	1 235 mm	2 150 mm
M1250	8 060 mm	1 100 mm	1 580 mm	1 980 mm	4 983 mm	5 168 mm	5 725 mm	1 565 mm	2 150 mm
M1250B	8 060 mm	1 100 mm	1 861 mm	1 980 mm	4 983 mm	5 168 mm	5 725 mm	1 565 mm	2 150 mm
M945	7 426 mm	950 mm	1 365 mm	1 980 mm	4 084 mm	4 297 mm	4 840 mm	1 565 mm	2 150 mm
M1045	7 426 mm	1 200 mm	1 615 mm	1 980 mm	4 084 mm	4 323 mm	4 865 mm	1 565 mm	2 150 mm
M1350	8 281 mm	1 200 mm	1 675 mm	2 150 mm	5 040 mm	4 988 mm	5 625 mm	1 700 mm	2 150 mm
M1350B	8 281 mm	1 200 mm	1 924 mm	2 150 mm	5 040 mm	4 988 mm	5 625 mm	1 700 mm	2 150 mm
M1450	8 281 mm	1 450 mm	1 925 mm	2 150 mm	5 118 mm	5 003 mm	5 639 mm	1 700 mm	2 150 mm
M1450B	8 281 mm	1 450 mm	2 174 mm	2 150 mm	5 118 mm	5 003 mm	5 639 mm	1 700 mm	2 150 mm
M1555	8 822 mm	1 350 mm	1 895 mm	2 150 mm	5 621 mm	5 545 mm	6 182 mm	1 895 mm	2 150 mm
M1655	8 822 mm	1 350 mm	1 895 mm	2 350 mm	5 621 mm	5 545 mm	6 182 mm	1 895 mm	2 150 mm
M1655B	8 805 mm	1 350 mm	2 228 mm	2 350 mm	5 621 mm	5 545 mm	6 182 mm	1 895 mm	2 150 mm
M1655T	8 805 mm	1 350 mm	2 060 mm	2 350 mm	5 621 mm	5 545 mm	6 182 mm	1 895 mm	2 250 mm
M1855	8 822 mm	1 600 mm	2 145 mm	2 350 mm	5 621 mm	5 561 mm	6 198 mm	1 895 mm	2 150 mm
M1855B	8 805 mm	1 600 mm	2 478 mm	2 350 mm	5 621 mm	5 561 mm	6 198 mm	1 895 mm	2 478 mm
M1855T	8 805 mm	1 600 mm	2 310 mm	2 350 mm	5 621 mm	5 561 mm	6 198 mm	1 895 mm	2 310 mm
M2070	10 155 mm	1 500 mm	2 190 mm	2 350 mm	6 921 mm	6 855 mm	7 492 mm	1 895 mm	2 250 mm
M2470	10 155 mm	1 750 mm	3 114 mm	2 350 mm	6 921 mm	6 870 mm	7 507 mm	1 895 mm	2 250 mm

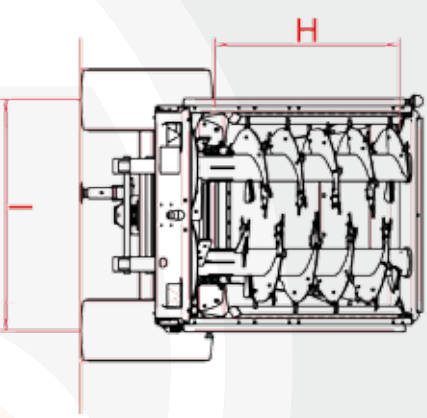
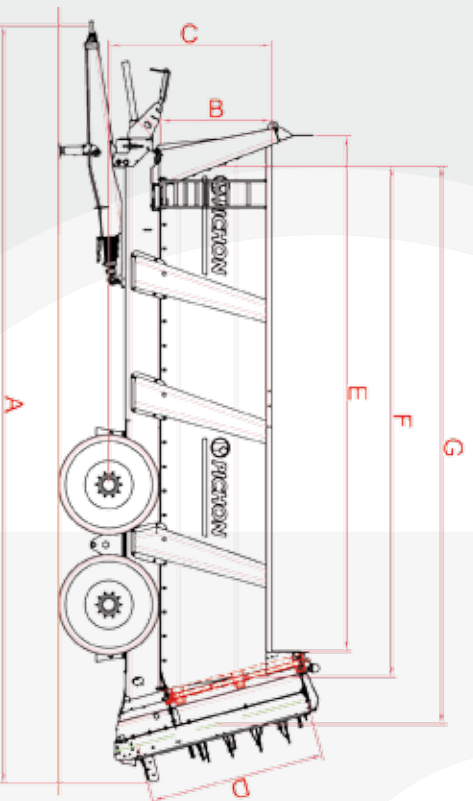
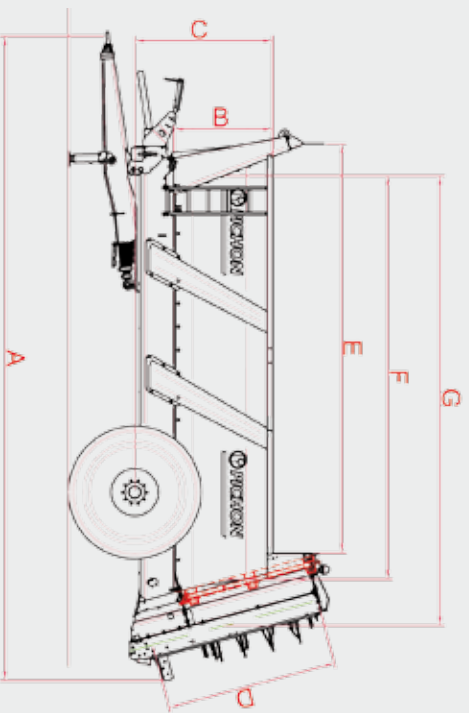



A PROFESSIONAL SERVICE AND A NETWORK TO SUPPORT YOU

SALES SERVICE

PICHON sales representatives are at your disposal to assist you in choosing the right equipment. Specialists in PICHON solutions, they can advise you and your customer in making of the ideal machine for your specific use. We invite you to meet them at agricultural fairs where PICHON are present or ask for their contact details at the factory.

DELIVERY

We deliver machines with our own fleet of trucks and our experienced drivers. Machines can also be despatched by containers worldwide.

ASSISTANCE FOR FIRST USE

You can benefit from our technical assistance for first use service. On site assistance is available on request.

AFTER-SALES SERVICE

Our qualified technicians are glad to assist our customers. You can download the assistance form request directly on our website.

SPARE PARTS

Our technicians can help you to find the parts within our large stock available. We have a wide choice of spare parts for PICHON range that can be despatched worldwide.

ONLINE

In addition to this brochure, we invite you to find more detailed information about our products on PICHON website.

You will discover many videos and pictures of our machines in use as well as the features of each range.

You can also find our latest news, the list of exhibitions we attend to as well as all our leaflets in PDF file.



www.pichonindustries.com



Discover our last videos on the Youtube PICHON channel: www.pichon.tv



DISCOVER OUR OTHER SOLUTIONS:



LIQUID SPREADING | SOLID SPREADING | TRANSPORT | HANDLING SOLUTIONS

PICHON DEALER:



BOULEVARD ANDRÉ MALRAUX - 29400 LANDIVISIAU - FRANCE

TEL: +33 (0)2 56 45 21 00 - FAX: +33 (0)2 56 45 21 20

email: info@pichonindustries.com

